



VEGETABLE PREPARATION MACHINE CA-2V 230/50-60/1

Compact, variable speed vegetable slicer. Brushless technology: maximum efficiency.



1050962



SALES DESCRIPTION

Compact ULTRA line. Variable speed motor block + vegetable slicer attachment.

Equipped with “brushless” technology: powerful and efficient motors.

- ✓ Maximum efficiency: maintain the torque throughout the speed range.
- ✓ Exclusive “force control system”: guarantee of a uniform and high quality result.
- ✓ Lightweight and compact design: they weigh less, they occupy less space.
- ✓ Improved air/water-tightness since no ventilation is required.
- ✓ They generate less noise: improved workplace environment.

A perfect cut.

- ✓ High precision settings and comprehensive cutter and disc design aimed at obtaining a perfect cut.
- ✓ Gravity product expulsion ramp allow to reconstruct the sliced product for storing or presentation purpose. (Watch video)
- ✓ Ejection disc included for the products that require its use.
- ✓ It can be fitted with a wide range of discs and grids of the highest cutting quality.
- ✓ Combining these accessories together to obtain more than 35 different types of cuts and grating grades. Exclusive “Force Control System” to optimise and standardise the cutting of each product: acoustic warning when the motor exceeds the pre-established force.
- ✓ Possibility of extending its functionality by adding the cutter bowl with blades.

Built to last

- ✓ Sturdy construction in food-grade best quality materials.

Maximum comfort for the user

- ✓ Ergonomic design: product sliced in one single movement.

- ✓ Lateral product output: requires less space on the worktop and guides the product, avoiding splashes.
- ✓ Adjustable product ejection direction to adapt to the workflow in the preparation area.
- ✓ Recessed cored relief allows for any position in the kitchen, side walls, back wall, light and compact, this machine can fit.
- ✓ Advanced control panel that is very intuitive to use and offers all the information at a glance.

Maintenance, safety, hygiene

- ✓ Lever and lid easily removable for cleaning purposes.
- ✓ Stainless steel, dishwasher-safe discs. The removable blades allow for an even more thorough and efficient cleaning.
- ✓ Combination of safety systems: head, cover, power switch.
- ✓ Complete error warning system.
- ✓ Appliance certified by NSF International (regulations on hygiene, cleaning and materials suitable for contact with foods).
- ✓ 100% tested.

INCLUDES

- ✓ Variable speed motor block.
- ✓ Vegetable slicer attachment.
- ✓ Gravity product expulsion ramp.
- ✓ Ejection disc.

OPTIONAL

- Cutter bowl.
- Hub with smooth blades.
- Hub with toothed blades.
- Hub with perforated blades.

ACCESSORIES

- Cutter bowl (Compact line)
- FCS Slicing Discs (Compact line)
- SHS Shredding & Grating Discs (Compact line)
- Hubs with blades (Compact)

SPECIFICATIONS

Hourly production: 350 Kg

Inlet opening: 89 cm²

Disc diameter: 180 mm

Speed as veg. slicer: 300 rpm - 1000 rpm

Total loading: 1100 W

Electrical supply: 230 V / 50-60 Hz / 1 ~ (6.5 A)

Plug: --

External dimensions (WxDxH)

Width: 378 mm

Depth: 309 mm

Height: 533 mm

Net weight: 12.9 Kg

Crated dimensions

285 x 385 x 714 mm

Volume Packed: 0.08 m³

Gross weight: 17.2 Kg

DYNAMIC PREPARATION
COMMERCIAL VEGETABLE PREPARATION MACHINES

product sheet
updated 18/05/2022



SAMMIC, S.L.
Bassate, 1 - 20729 Azzimino
www.sammic.com



VEGETABLE PREPARATION MACHINE CA-2V 230/50-60/1

Compact, variable speed vegetable slicer. Brushless technology: maximum efficiency.



1050962

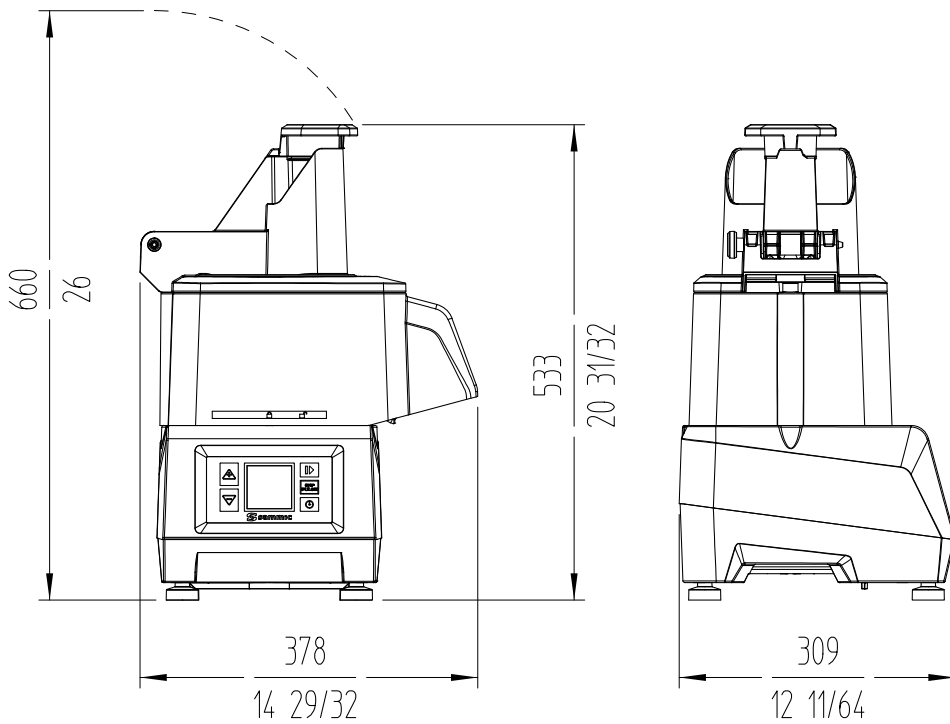

DYNAMIC PREPARATION
COMMERCIAL VEGETABLE PREPARATION MACHINES



www.sammic.co.uk
Food Service Equipment Manufacturer
 Unit 2, Trevanah Road
 Troon Industrial Park
 LE4 9LS - Leicester
 uksales@sammic.com
 Tel.: +44 0116 246 1900



Project	Date
Item	Qty
Approved	

product sheet
updated 18/05/2022